

## GIYOTIN TIP BULASIK YIKAMA MAK. MEKANİK OBM 1080M P

Sayfa 1

Version No: V20.11

071M.10000.BB

## YEDEK PARÇA L STES

Yedek Parça Madde Kodu	madde adı.	ResimNo	Fiyat.	ParaB.
9099.01000.13	REZISTANS HOOD TYPE TANK REZISTANSI 2000W 230V			
6262.00021.071	HORTUM IC CAP 45 mm x 60 mm x 188 mm GECISLI KAUCUK 1080 T/S H TIP UZUN SASE			
6262.00033.06	BYM 1080 YIKAMA BORUSU UST PARÇASI SOMUNU			
6262.00025.03	BYM 1080 UST YIKAMA/DURULAMA DIRSEK PLS. (YENI)			
6262.00041.03	POLİPROPİLEN YIKAMA/DURULAMA MILİ 35/40/500/1080/OKY YENİ MODEL INOX-304			
6262.00028.07	TAHLİYE TAPASI PLASTİK (YARIM KAZAN / UZUN SASE) 334 mm / OBM 1080			
6226.00004.040	LASTİK CONTA SIYAH DIS 69 x IC 55 x K 4,5 mm (ORTA GOBEK 1080 / 500 / BARDAK)			
2710.F1000.03	BYM 1080 BOILER KAZANI (OZTI HOOD TYPE)			
2710.50109.B02	BYM 1080 HOOD TYPE TERMOSTAT BAĞLANTI SACI			
6228.00001.35	ORING Q 35 x 1,5 mm YIKAMA BORUSU UST DIRSEK BAĞLANTISI			
6226.00004.07	CONTA EMİS FİLTRESİ DIS 138 x IC 114 x K 4,5 mm			
6262.00022.13	BYM 1080 HOOD TYPE BORU KOL SABİTLEME PLASTİK			
6231.00019.46	ROLE ZAMAN EMKO-BYM-01 (MAVİ RENK - 50 / GIYOTIN)			
9099.L80T7.5SX	BYM OLYMPIA 500 / GIYOTIN YIKAMA POMPASI (L80.T75SX)			
6228.00001.110	ORING Q 35 x 2,5 mm VİTON (BYM 1080 UST YIKAMA BORUSU İCİN)			
6228.00001.36	ORING Q 35 x 2,5 mm BYM TAHLİYE TAPASI İCİN			
6262.00021.78	HORTUM BASKILI DURULAMA Y PARÇA HOOD TYPE OBM 1080 (Rekorlu 570x630x570 mm) UZUN SASE			
6262.00024.04	OBY 35 / 40 / 50 / 1080 / OKY PLASTİK YIKAMA GOBEK SOMUNU			
6262.00041.04	YIKAMA MILİ SAPKASI M8*10mm 6K INOX			
6262.00033.33	BULASIK YIKAMA/DURULAMA FİSKİYE (5 GOZLU) KOMPLE PLAS. (YENİ)			
6262.00027.07	EMİS FİLTRESİ UST PARÇA (500/1080/1500/2000 T/S)			
6262.00003.20	KIZAK MAKARASI 1080 T/S			
6606.00001.12	KABLO GECİS.LASTİGİ İC8 DIS 16MM			
6262.00021.18	HORTUM 1/2" SARGILI BEZLİ 125o ısı/15 bar'a dayanıklı			
6262.00027.05	EMİS FİLTRESİ ALT PARÇA (500/1080/1500/2000 T/S)			
6221.00001.020	KELEPCE 12*20MM (430 KALİTE)			
6221.00001.030	KELEPCE 32*50MM (430 KALİTE)			
2710.11001.10	BYM 1080 HOOD TYPE ALT SASE MEKANİK ON PANEL YARIM KAZAN			
6251.00004.48	SİNYAL LAMBASI AN-EL S 49(SEFFAF)			
2710.57885.01	BYM 1080 HOOD TYPE OZTIRYAKILER SEPET OTURAGI KOMPLE			
6226.00006.02	CONTA HAVA KAPANI SİLİKON GRİ (YENİ)			
6262.00021.13	HORTUM TAHLİYE SAN TIP Q30-250CM.BOY CİFT BASLIKLİ			
6222.00027.01	CEKVALF PLASTİK DN20 (20MM 3/4" PLASTİK VENTİL İCİN)			
6262.00020.31	KULLANMA KLAVUZU (KÜSE KAGIT) (1080 DİJİTAL) TÜRKÇE			
2710.F0001.01	BYM MİKNATIS ve MUHAFAZA TOPLANMIS			
6232.00005.10	MANYETİK SENSÖR MM-B12-YA (OZTI)			
6262.00007.00	PRESOSTAT 85-60 (1080 MEKANİK / 1500 / 2000 / 3000 / OKY)			
9099.00011.41	BUTON BLUE KALİCİLİ MAVİ POWER LOGOLU (LEDLİ DUGME ONPOW / DAILYWELL KPB22-88P1-F11-7220			
2710.1080H.05	HOOD H TYPE YARIM KAZAN PASLANMAZ KİRİNTİ SUZGEC (25 LT)			
2710.10002.21	BYM 1080 HOOD H TYPE GECMELİ ARKA KAPAK SACI			
9099.00011.42	BUTON BLUE KALİCİLİ MAVİ RENK (LEDSİZ DUGME ONPOW / DAILYWELL KPB22-8700-F11-7220-JQ-VE)			
6234.00001.037	TERMOSTAT AYNA+KAPAK 30-120 C (EGO)			
6262.00071.37	KOMİTATOR DUGMESİ Q6 mm (YARIM KAZAN 1080 KNOB) SERİGRAFI BASKISI DAHİL GRİ			
6262.00026.03	PLS HAVA KAPANI (YENİ)			
6221.00001.040	KELEPCE 40*60MM (430 KALİTE)			
6262.00033.04	BYM 1080 YIKAMA BORUSU UST PARÇASI			
6262.00030.05	YIKAMA KOLU TABLASI PLASTİK (SU YONLENDİRİCİ HALKA)			
6262.00003.06	KIZAK MAKARASI CİVATASI EKO1000/1080 T/S(16"LIK MALZ INOX)			
6221.00001.050	KELEPCE 50*70MM (430 KALİTE)			
6262.00024.03	OBY 35 / 40 / 1080 / OKY PLASTİK YIKAMA GOBEK			
6226.00021.13	TAHLİYE HORTUM CONTASI (BUYUK)			
9099.FPD18.0A	PLS VENTİL 3/4 TEKLİ FPD180A G3/4_D12 / 220-240V 50/60 Hz (YINHAO/CEKVALFLI)			
6262.00027.06	EMİS FİLTRESİ ORTA PARÇA (500/1080/1500/2000 T/S)			
6262.30666.013	PARLATICI POMPASI CEKVALF (INOX GIRISLI)			
6262.00021.38	YIKAMA HORTUMU BASKILI 1080 HOOD H TYPE GIYOTIN (UZUN SASE) EPDM			
9099.00001.85	TERMOSTAT LİMİT RESETSİZ 75 C (MERCİMEK TIP) T1/11-75/55C			
6226.00004.030	LASTİK CONTA SIYAH İNCE (DIS 72 x IC 45 x K 3 mm EPİDYEN)(1080 TS UST DIRSEK İCİN)			
2710.50108.B01	OBY 35/40/50/100 PARLATICI - DETERJAN BAĞLANTI SACI	51		
9999.B08RE.00	PARLATICI POMPASI GIADOS MAKİNE İCİ ELEKTRİK Lİ B08REG 0,8LT/H	52		
9099.01000.06	REZİSTANS 9000 W UÇGEN FLANS İRCA İNCOLOY 800 ( 1080-1500-2000 BOILER )	72		
6232.00027.00	ANAHTAR AN-EL SAC GÖVDELİ CERCEVELİ RTH 401 5013.00 12MM M.P.	82		
9234.00001.68	TERMOSTAT 170 C LİMİT FSTB WYF170G-ZS4	84		
6234.00001.019	TERMOSTAT 30-120°C FSTB WYG120S-061	85		
2710.10003.09	BYM 1080 HOOD TYPE ELEKTRİK PANOSU RAKORSUZ SURGULU	94		
6260.00002.10	BORU AYAK 130-180MM UST TABLA 90*100	LG10		

öztiryakiler

GIYOTIN TIP BULASIK YIKAMA MAK. MEKANIK OBM 1080M P

071M.10000.BB

Sayfa 2  
Version No: V20.11

9099.00004.17

MIKNATIS D18\*D6\*10MM N35\_NICUNI NEODYMIUM

MGT4

V 20.11

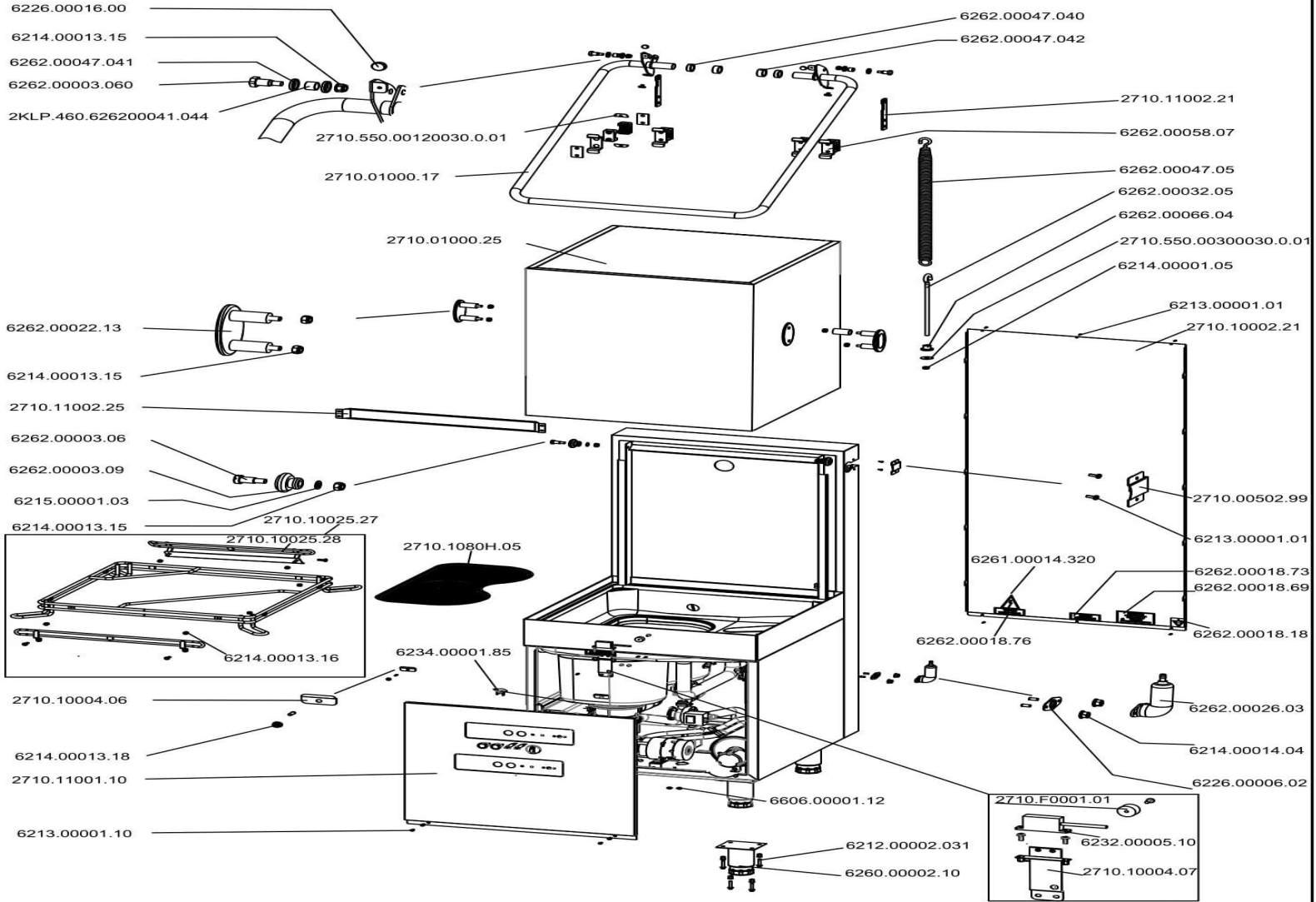

R&D	NAME	SIGNATURE	DATE	MATERIAL	VERSION NO	OZTI	
DRAWING	S.GURCU		10.02.2020		V 20.11	GROUP NAME: 1080 BODY GROUP EXPLODED VIEW	
CONTROL	S.GURCU		10.02.2020			PICTURE NO	
CONSENT	M.HACI		10.02.2020	THICKNESS	REVISION		
				WEIGHT (gr.)	SCALE		
MEASUREMENTS MILIMETER							

**V 20.11**

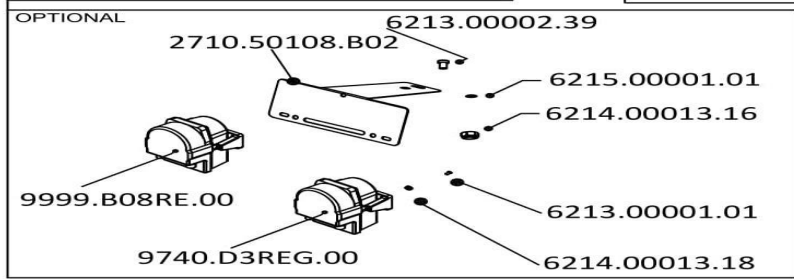
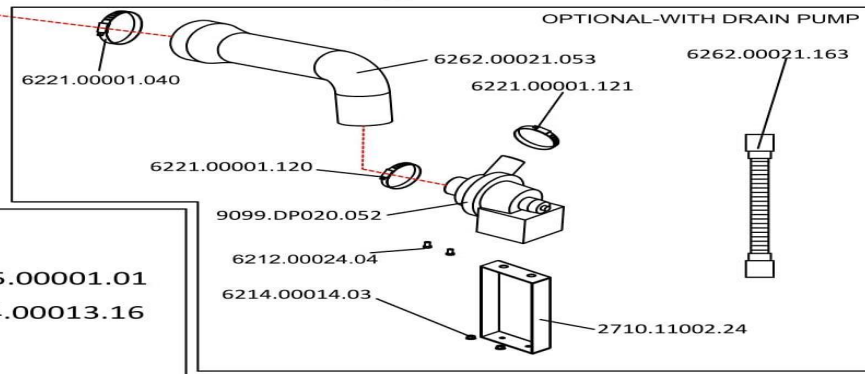
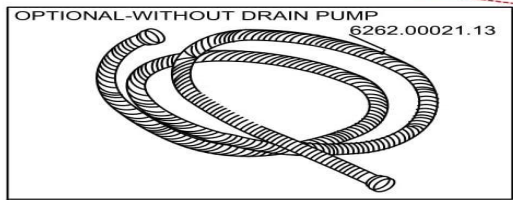
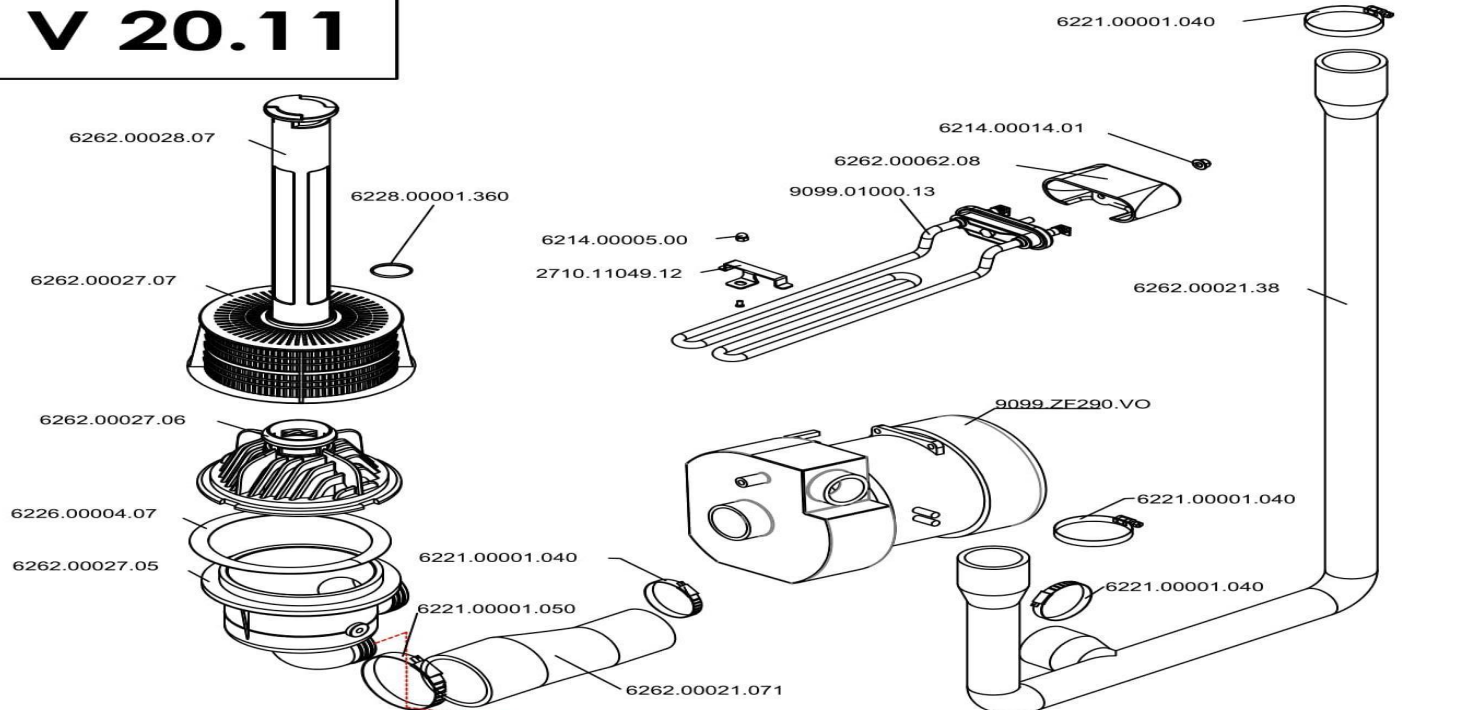

R&D	NAME	SIGNATURE	DATE	MATERIAL	VERSION NO
DRAWING	S.GURCU		10.02.2020		<b>V 20.11</b>
CONTROL	S.GURCU		10.02.2020		
CONSENT	M.HACI		10.02.2020		
MEASUREMENTS MILIMETER		THICKNESS		REVISION	
WEIGHT (gr.)		SCALE		GROUP NAME: WASHING GROUP EXPLODED VIEW	
PICTURE NO					

**OZTI**

**V 20.11**

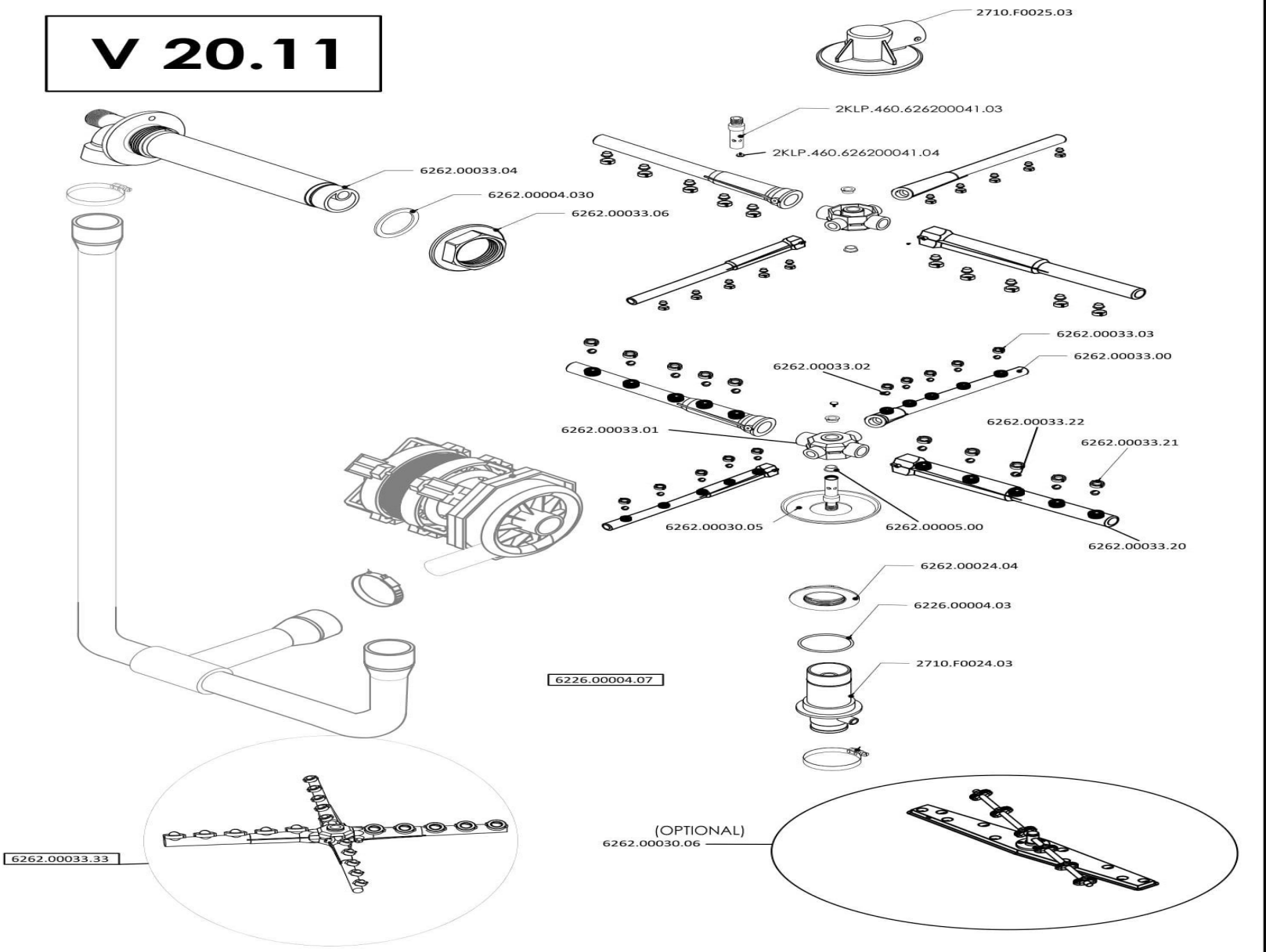

R&D	NAME	SIGNATURE	DATE	MATERIAL	VERSION NO	<b>OZTI</b>				
DRAWING	S.GURCU		10.02.2020		<b>V 20.11</b>					GROUP NAME: SPRAY ARM GROUP EXPLODED VIEW
CONTROL	S.GURCU		10.02.2020	THICKNESS	REVISION	PICTURE NO				
CONSENT	M.HACI		10.02.2020	WEIGHT (gr.)	SCALE					
MEASUREMENTS MILIMETER										

V 20.11

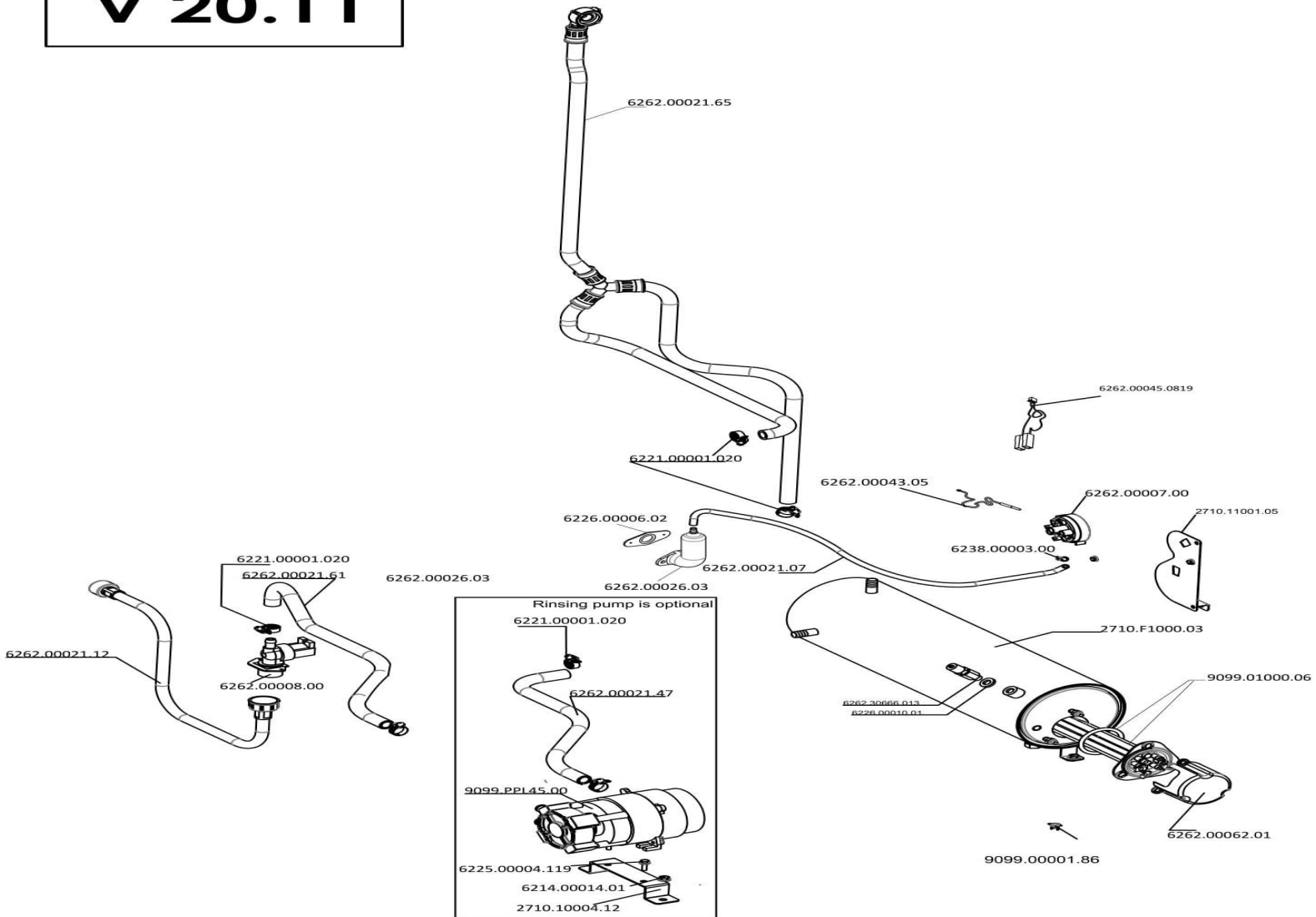

R&D	NAME	SIGNATURE	DATE	MATERIAL	VERSION NO
DRAWING	S.GURCU		10.02.2020		<b>V 20.11</b>
CONTROL	S.GURCU		10.02.2020		
CONSENT	M.HACI		10.02.2020		
		MEASUREMENTS MILIMETER		THICKNESS	REVISION
				WEIGHT (gr.)	SCALE

**OZTI**

GROUP NAME: RINSING GROUP EXPLODED VIEW

PICTURE NO



V 20.11

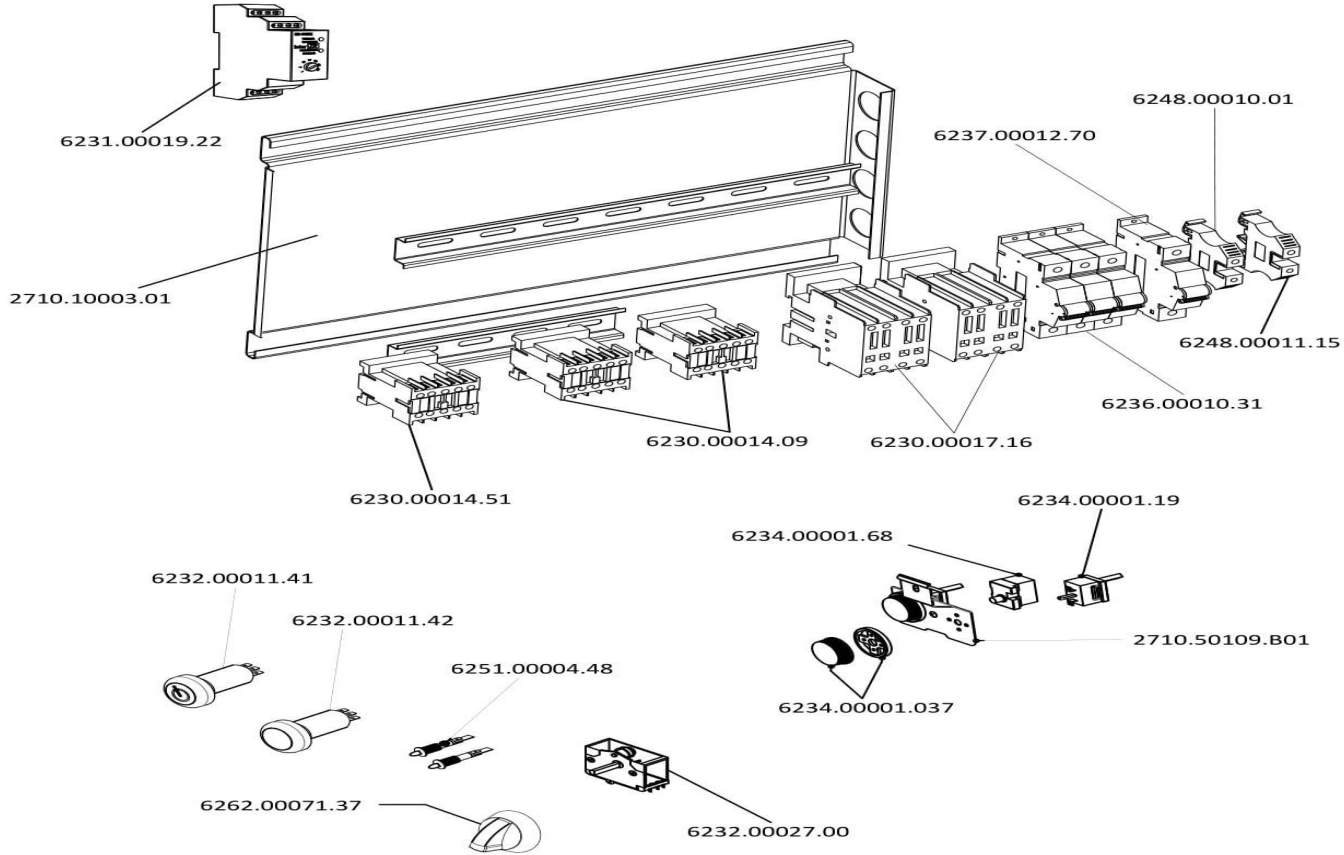

R&D	NAME	SIGNATURE	DATE	MATERIAL	VERSION NO	OZTI	
DRAWING	S.GURCU		10.02.2020		V 20.11	GROUP NAME: ELECTRICAL GROUP EXPLODED VIEW	
CONTROL	S.GURCU		10.02.2020		REVISION	PICTURE NO	
CONSENT	M.HACI		10.02.2020	THICKNESS	SCALE		
			MEASUREMENTS MILIMETER	WEIGHT (gr.)			