

ATTENZIONE: PER TENSIONI SPECIALI, SPECIFICARE SEMPRE IL MODELLO DI FORNO ED IL NUMERO DI MATRICOLA
ATTENTION: FOR SPECIAL VOLTAGES, PLEASE ALWAYS SPECIFY THE OVEN MODEL AND THE SERIAL NUMBER

ATTENTION: POUR TENSIONS SPÉCIALES, MERCI DE SPÉCIFIER TOUJOURS LE MODÈLE DU FOUR ET LE NUMÉRO DE SÉRIE
ACHTUNG: BEI SONDRSPANNUNGEN, BITTE IMMER OFEN-MODELL UND SERIENNUMMER GEBEN.

ed. 0713

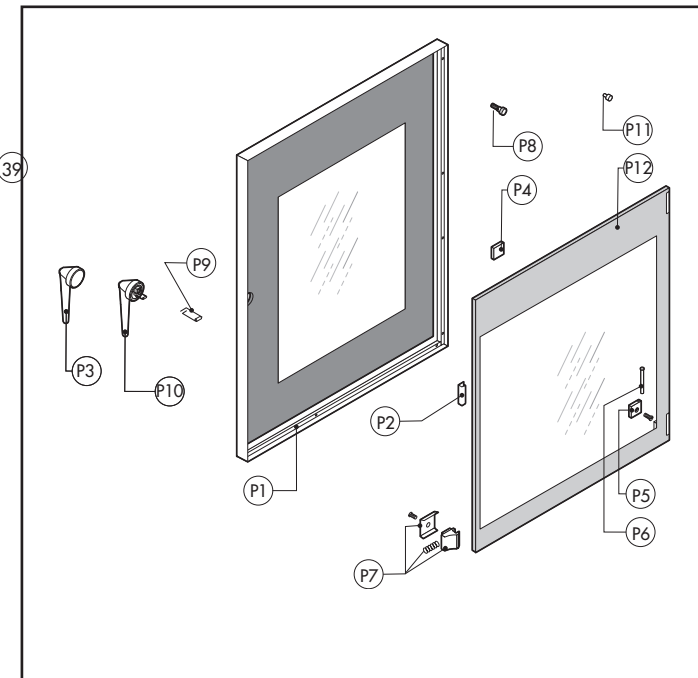
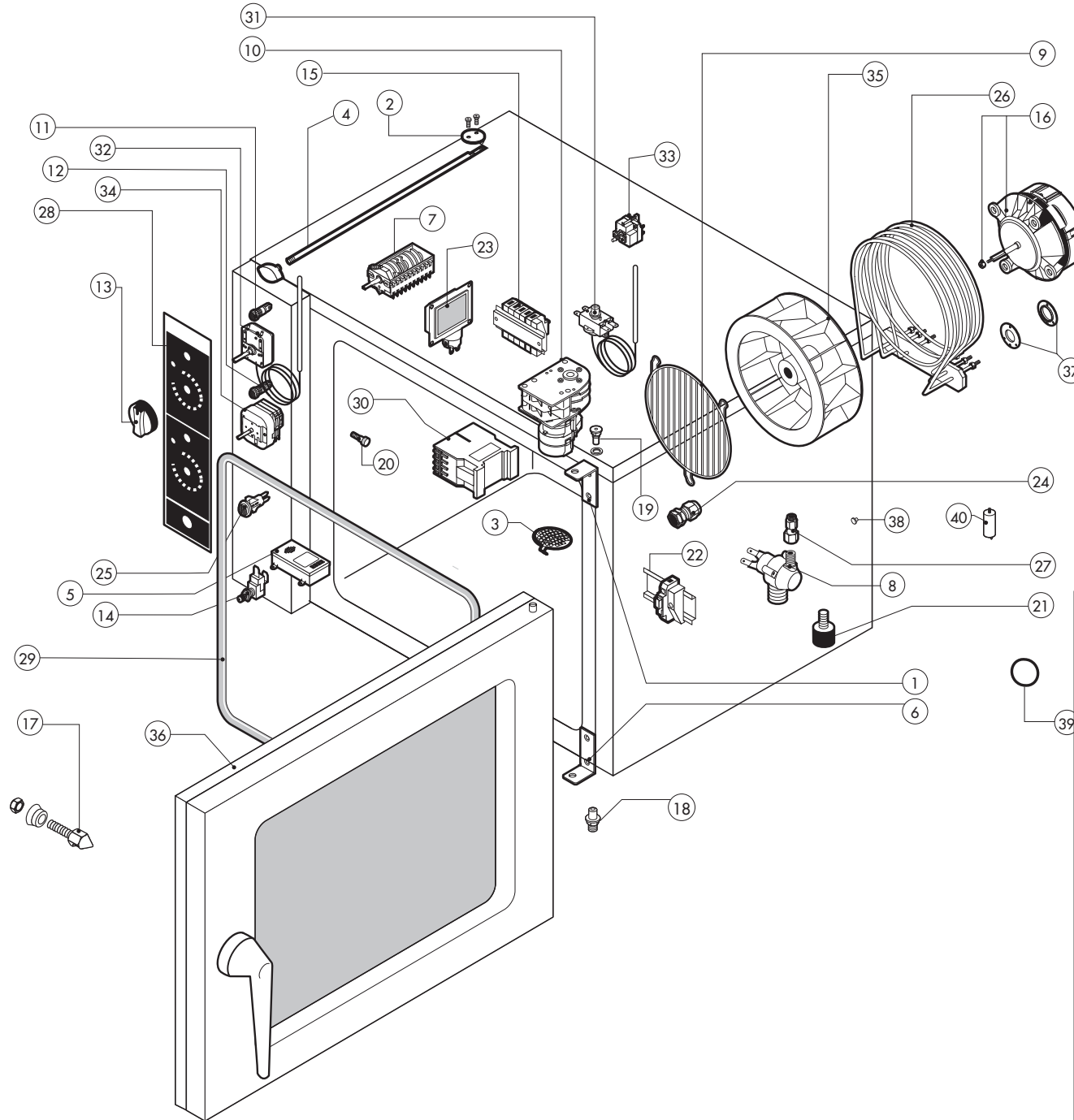

ATTENZIONE: PER ORDINARE I RICAMBI, SPECIFICARE SEMPRE IL MODELLO DI FORNO ED IL NUMERO DI MATRICOLA
ATTENTION: WHEN ORDERING SPARE PARTS, PLEASE ALWAYS SPECIFY THE OVEN MODEL AND THE SERIAL NUMBER

ATTENTION: POUR COMMANDER DES PIÈCES, MERCI DE SPECIFIER TOUJOURS LE MODÈLE DU FOUR ET LE NUMÉRO DE SÉRIE
ACHTUNG: UM ERSATZTEILE ZU BESTELLEN, BITTE IMMER OFEN-MODELL UND SERIENNUMMER GEBEN.

ed. 0713

POS.	COD.	Pz.	DESCRIZIONE	DESCRIPTION	DESCRIPTION	BESCHREIBUNG	DESCRIPCIÓN
1	R17201110	1	ASS.CERNIERA SUP.PORTA REC-REV-REP 2011	UPPER HINGE	CHARNIERE SUPERIEUR	OBERES SCHARNIER	BISAGRA SUPERIOR
2	R18200600	1	ASS.FARFALLA M_042/051 REV M	CHAMBER VENT PLATE	ENTFEUCHTUNGSSCHIEBER	DISQUE EVENT	DISCO RESPIRADERO
3	R10201700	1	ASS.FILTRO DI SCARICO D.76/44.5 M/106-11	DRAIN FILTER	FILTRE ENCEINTE	ABFLUSSFILTER	FILTRO DESAGUE
4	R58003560	1	ASTA SFIATO REV 051/071/101 M	CHAMBER VENT ROD	BARRE COMMANDE EVENT	SCHIEBERACHSE	EJE RESPIRADERO
5	R65330050	1	BUZZER TEMPOR.3" 230V C/SCAT. .	BUZZER 3"	SONNERIE 3"	SUMMER MIT ZEITGLEID	ZUMBADOR TEMPORIZADO 3"
6	R17403910	1	CERNIERA INF. PORTA REGOL.REC-REV-REP	LOWER HINGE	CHARNIERE INFERIEUR	UNTERES SCHARNIER	BISAGRA INFERIOR
7	R65080020	1	COMMUTATORE 5 POS.-SERIE 7LA COD.88.0900	MAIN SELECTOR SWITCH	COMMUTATEUR	SCHALTER	CONMUTADOR
8	R65110200	1	E.V. 1 VIA 220V 50HZ X J.G.CON ATTACC	SOLENOID VALVE 220V 50HZ	ELECTROVANNE 220V 50HZ	MAGNETVENTIL 220V 50HZ	ELECTROVALVULA 220V 50HZ
9	R75300150	1	GRIGLIA VENTILATORE D.170	FAN GUARD GRID D.170	GRILLE VENTILATEUR D.170	VENTILATORSCHUTZGITTER D.170	REJILLA VENTILADOR D.170
10	R65090170	1	INVERSORE CICLICO 8' 3 CAMME	REVERSING SWITCH	INVERSEUR	POLWENDER	INVERSOR CICLICO
11	R65270300	2	LUCE SPIA GIALLA ALPHATECH SL 656 TZB	ORANGE INDICATING LIGHT	LAMPE TEMOIN ORANGE	ORANGENE KONTROLLAMPE	LAMPARA PILOTO NARANJA
12	R65270320	1	LUCE SPIA VERDE ALPHATECH SL 656 TZA	GREEN INDICATING LIGHT	LAMPE TEMOIN VERT	GRUENE KONTROLLAMPE	LAMPARA PILOTO VERDE
13	R69030130	3	MANOPOLA BLU/BLU D.42	KNOB KIT	POIGNEE COMMANDE	DREHKNOPF	PULSADOR MANETA
14	R65260540	1	MICRO PORTA	DOOR SWITCH	MICRO PORTE	TUERSCHALTER	MICRO PUERTA
15	R65220091	1	MORSETTIERA LX2E (TIPO 2) NEW	TERMINAL BOARD	BORNIER	KLEMMLEISTE	REGLETERA
16	R65041010	1	MOTORE 1F.200W 2VEL(C/COND.)C06110	MOTOR	MOTEUR	MOTOR	MOTOR
17	R69010260	1	NASELLO 1 STEP 6303-020022	DOOR LATCH 1 STEP	GACHE DE PORTE POUR OUVERTURE SIMPLE	SCHLISSNASE 1 STUFE	NARIZ 1 CIERRE
18	R58002520	1	PERNO INF.CERNIERA REG. V/061-102	LOWER HINGE PIN	CHEVILLE CHARNIERE INFERIEURE	UNTERES SIE SCHARNIERSTIFT	PERNO INFERIOR BISAGRA
19	R58002150	1	PERNO SUP.CERNIERA REG. M/106-220	UPPER HINGE PIN	CHEVILLE CHARNIERE SUPERIEURE	OBERES SCHARNIERSTIFT	PERNO SUPERIOR BISAGRA
20	R58001850	8	PERNO SUPP. PARATIE M5 MIXTER	RACK HOLDER	BOLZEN AUFLAGESCHIENEN	SUPPORT GLISSIERE	PERNO SOPORTE MAMPARO
21	R69070220	4	PIEDINO INOX+NYLON D.40 H TOT.60 FIL.M10	FOOT	VERIN	ZYLINDRISCHER FUSS	PIE ACERO
22	R65210020	2	PORTAFUSIBILE BARRA DIN 5x20	FUSE CARRIER	PORTE-FUSIBLE	SICHERUNGSHALTER	PORTAFUSIBILE
23	R65270510	1	PORTALAMPADA STAGNO ALPHATECH 77.705.U10	WATERPROOF LIGHT SOCKET	DOUILLE ETANCHEE	DICHTE LAMPEHALTERUNG	PORTALAMPARA ESTANCO
24	R65240200	1	PRESSACAVO V-TEC 21 NERO	FAIRLEAD	PRESSE CABLE	ZUGENTLASTUNG	PRENSACABLES
25	R65260520	1	PULSANTE COMANDO UMIDIFICATORETIPO SPL60	HUMIDIFIER PUSH BUTTON	TOUCHE HUMIDIFICATEUR	BESCHWADUNGSDRUCKTASTE	PULSADOR UMIDIFICADOR
26	R65011730	1	RESIST.7000W230V CAM. ALPHA INCOLOY800	HEATING ELEMENT	RESISTANCE	HEIZKOERPER	RESISTENCIA
27	R62090788	1	RIDUZIONE INTER.DRITTA ø10-ø6 PM201006E	REDUCTION	REDUCTION	VERRINGERUNG	REDUCCION
28		1	TASTIERA	PLATE	PLAQUE	BEDIENUNGSFOLIE	TARJETA
29	R70044340	1	TELAIO GUARN. PORTA A V-C 05	FRONT GASKET	JOINT FACADE	DICHTUNG DER FRONTSEITE	JUNTA FRONTAL
30	R65140380	2	TELERUTTORE 3RT1016-1AP02	CONTACTOR	CONTACTEUR	SCHUETZ	CONTACTOR
31	R65070460	1	TERMOST.SICUR.BIP.360°C NEGAT.	THERMOSTAT	THERMOSTAT	THERMOSTAT	TERMOSTATO
32	R65070400	1	TERMOSTATO 50/300°C KT 170 CLA	THERMOSTAT 50/300°C	THERMOSTAT 50/300°C	THERMOSTAT 50/300°C	TERMOSTATO 50/300°C
33	R65070165	1	TERMOSTATO 65°C	THERMOSTAT	THERMOSTAT	THERMOSTAT	TERMOSTATO
34	R65090090	1	TIMER ELETTRON.120' C/POS.MAN.MS65 6935A	TIMER	MINUTERIE	ZEITSCHALTUHR	TEMPORIZADOR
34	R65090110	1	TIMER ELETTRON. 120' C/POS. M. 1.4000F3120ME0 DALLA SETTIMANA 27/2013	TIMER FROM WEEK 27/2103	MINUTERIE DU SEMAINE 27/2013	ZEITSCHALTUHR VOM WOCHEN 27/2013	TEMPORIZADOR DEL SEMANA 27/2013
35	R75400410	1	VENTOLA D.180X77/12 50HZ P.D.	FAN	TURBINE	LUEFTERRAD	PALA VENTILADOR
36	R17102610	1	PORTA COMPLETA REV-RGV051 LX	DOOR ASSEMBLY	PORTE COMPLETE	TUER KOMPLETT	PUERTA COMPLETA
	R17105400	1	PORTA COMPLETA SERIGRAFATA REV-RGV051 AT	DOOR ASSEMBLY	PORTE COMPLETE	TUER KOMPLETT	PUERTA COMPLETA
37	R58005500	1	FLANGIA GUARNIZIONE MOTORE	MOTOR GASKET BRASS FLANGE	BRIDE JOINT MOTEUR	FLANSCH F. MOTORDICHTUNG	BRIDA JUNTA MOTOR
38	R65110500	1	REGOL. PORT. MARR. ATCH. 10L/h	10 LT/H WATER FLOW REDUCER	REGULATUER DE DEBIT 10 LT.	DURCHFLOSSMONDERER 10L/STD.	REGULADOR DE CAUDAL 10 LT.
39	R70010140	1	GUARNIZIONE SILICONE ROSSO 76x40,3x3	RED GASKET 76x40,3x3	ROUGE JOINT 76x40,3x3	ROTEN DICHTUNG 76x40,3x3	JUNTA ROJA 76x40,3x3
40	R65190080	1	CONDENSATORE 5 µF	CAPACITOR	CONDENSATEUR	KONDENSATOR	CONDENSADOR

TAV. A

REV 051 M

